



DSS DLMS Migration

UID/DLMS Migration Workshop, Washington DC, 9-10 March 04

Presented by
Mr. Jeff Charlesworth
jcharlesworth@dcdc.dla.mil IT Chief
DLA
Systems Integration Office, DSIIO-U
1



Agenda

- Background on DSS and DLMS
- The DSS Approach to DLMS
- Challenges and Lessons Learned



Background

- **Distribution Standard System (DSS)**
 - Standard system performing wholesale logistics for the Defense Logistics Agency
 - Supports the mission of the Defense Distribution Center
 - Interacts with many DoD logistics systems including BSM, SAMMS, UICP, UADPS-2, LMP CCSS, AMCISS, D035K, LOGSA, FLIS, etc



Background Cont.

- Distribution Standard System (DSS)
 - Sends out approximately 1.5 million transaction per day
 - Receives approximately 500,000 transaction per day



DSS's Need For DLMS

- Navy requested that DLA be able to receive, store and issue material by a Unique Item Identifier (UII/serial number)
- The size of this number is thirty positions, and needed to be recorded in transactions such as the Due In, Shipment Status, etc
- DLMS was the most viable solution



Preliminary Steps to DLMS

- Identified all MILs transactions
- Identified the DLMS equivalent
- Worked with DLMSO and the DLMSO Implementation Convention for data placement
- Worked with DAASC for Logical Data Maps



Former MILS Processing

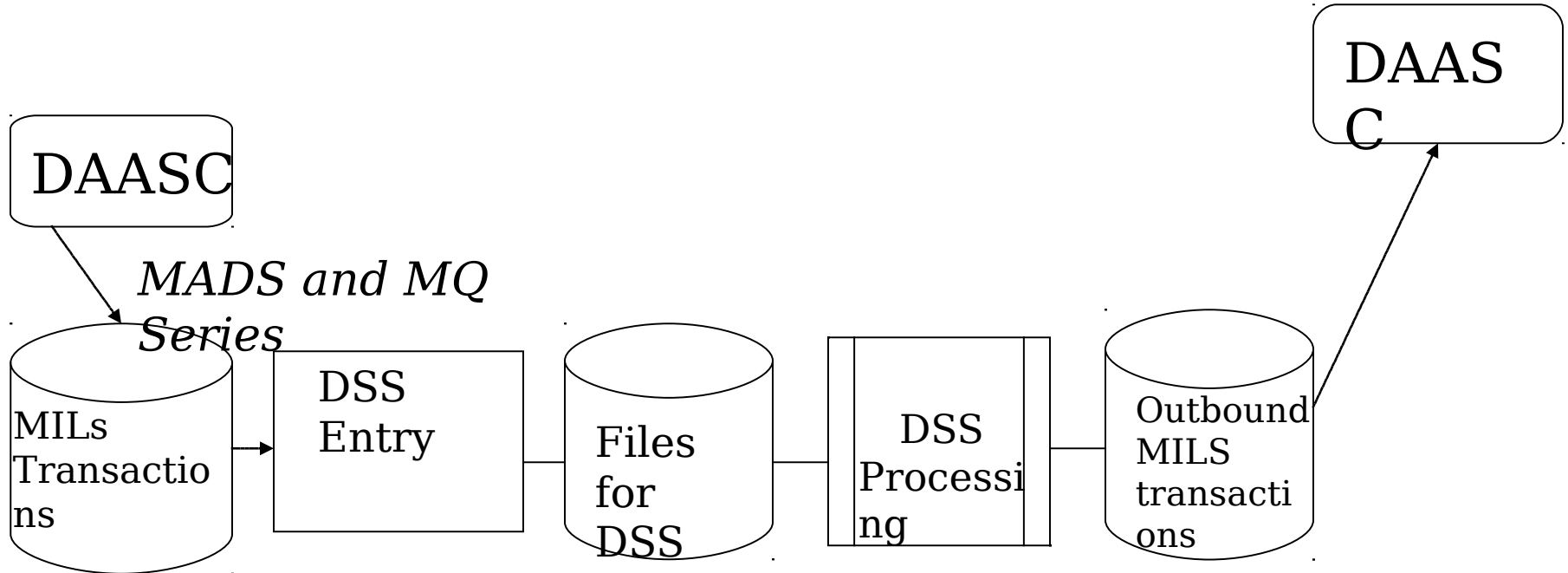



DLMS Inbound Processing

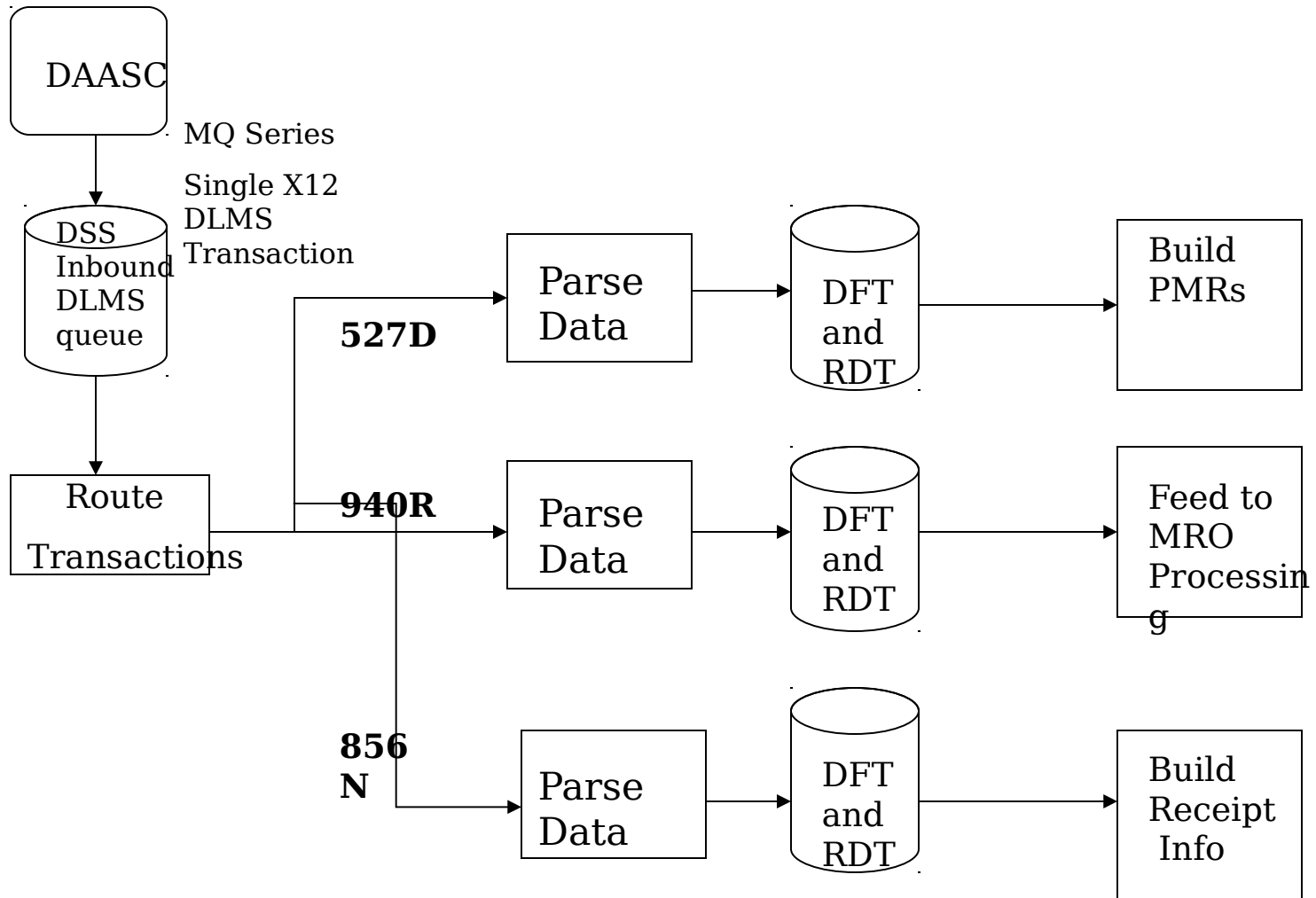



DLMS Outbound Processing

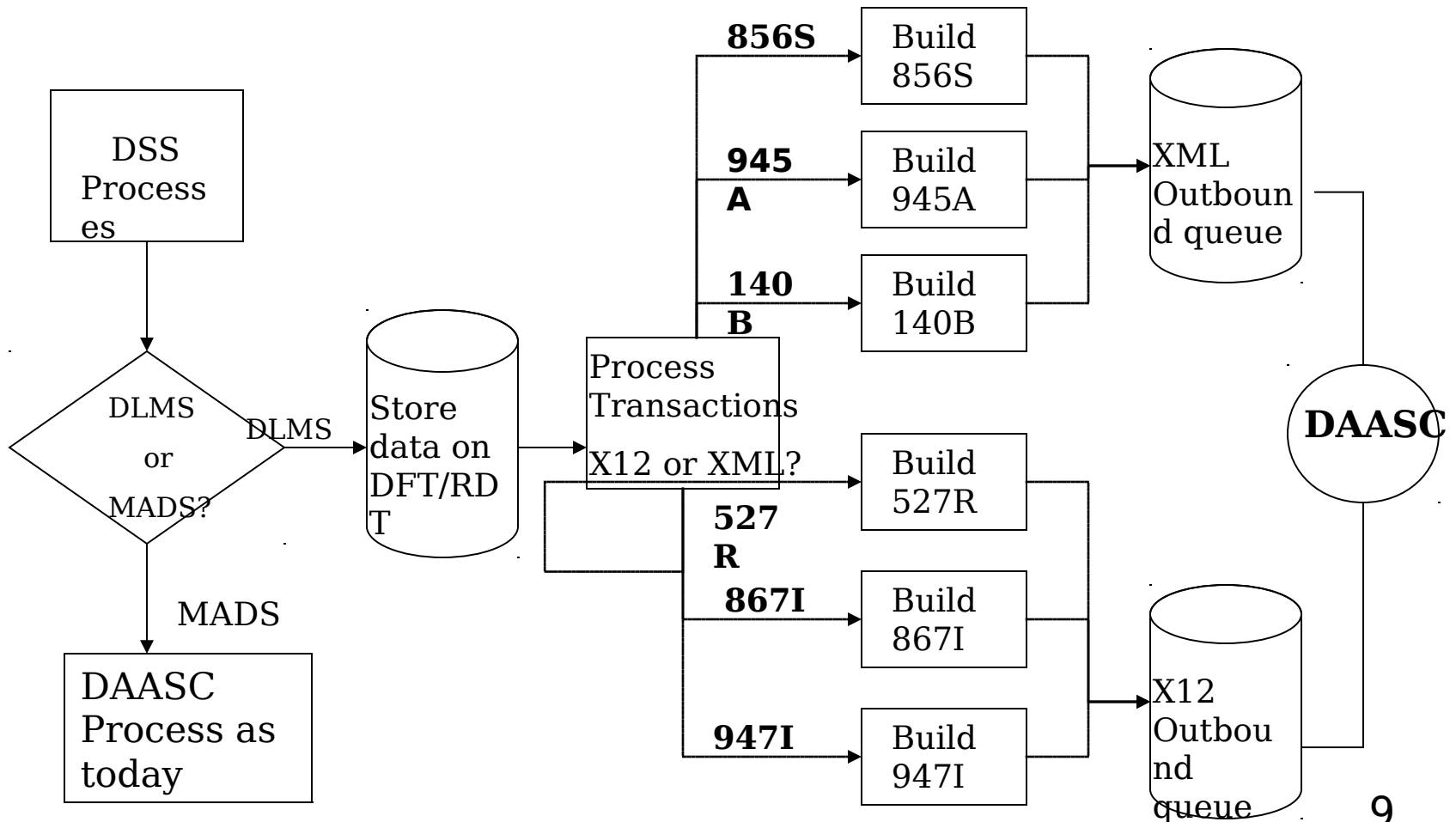



DAASC Processing

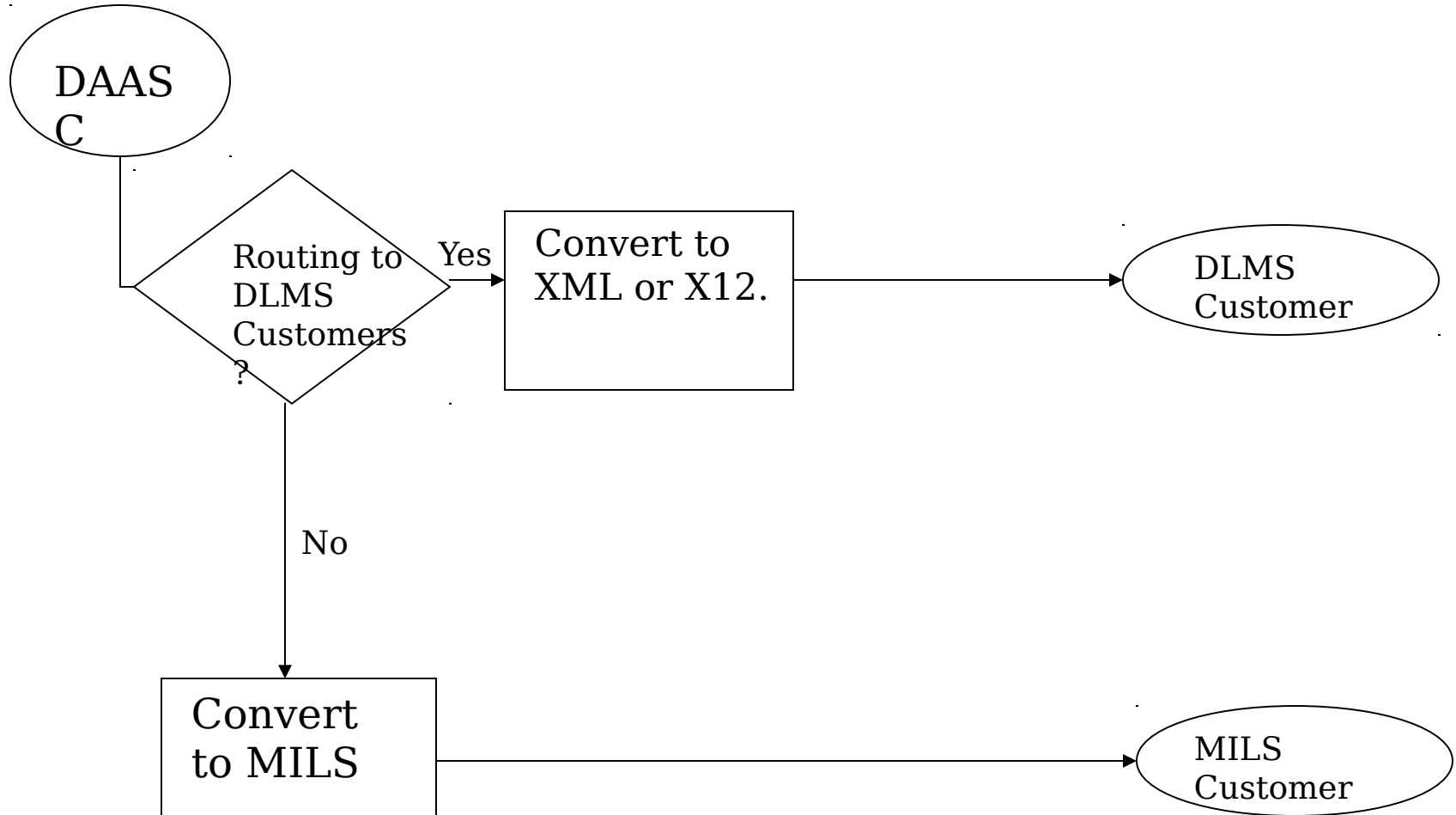



Challenges

- Planning
- Amount of Detail is Time Consuming
- Testing Presents Challenges
- Standardization of XML
Implementation Convention



Lessons Learned

- Create a table driven DLMS/MILs On/Off Switch
- Detailed Requirements Analysis Upfront
- DLMSO and DAASC are key
- Trading Partner Coordination



DLSS Formats Converted

<u>MILs</u>	<u>DLMS</u>	<u>MILs</u>	<u>DLMS</u>	<u>MILs</u>	<u>DLMS</u>
D4M	527R	DWZ	527D	AFT	940R
D4S	527R	D8A	947I	AFX	940R
D4U	527R	D8B	947I	AFZ	940R
D4V	527R	D8C	947I	AK6	940R
D4X	527R	D8D	947I	AKJ	940R
D4Z	527R	D8E	947I	AM1	940R
DUM	527D	D8F	947I	AM2	940R
DUS	527D	D8J	947I	AM4	940R
DUU	527D	D8K	947I	AM5	940R
DUV	527D	D8S	947I	AMA	940R
DUX	527D	D8Z	947I	AMB	940R
DUZ	527D	D9A	947I	AMD	940R
D6A	527R	D9B	947I	AME	940R
D6B	527R	D9C	947I	A61	945A
D6C	527R	D9D	947I	A62	945A
D6D	527R	D9E	947I	A64	945A
D6E	527R	D9F	947I	A65	945A
D6G	527R	D9G	947I	A67	945A
D6H	527R	D9H	947I	A6A	945A
D6J	527R	D9J	947I	A6B	945A
D6K	527R	D9K	947I	A6D	945A
D6L	527R	D9S	947I	A6E	945A
D6M	527R	D9Z	947I	A6I	945A



DLSS Formats Converted

<u>MILs</u>	<u>DLMS</u>	<u>MILs</u>	<u>DLMS</u>	<u>MILs</u>	<u>DLMS</u>
D6N	527R	PK5	856	AE6	945A
D6Q	527R	PKN	861A	AEJ	945A
D6R	527R	PKP	861A	AG6	945A
D6T	527R	A21	940R	AGJ	945A
D6U	527R	A22	940R	AR0	945A
D6V	527R	A24	940R	ARA	945A
D6X	527R	A25	940R	ARB	945A
D6Z	527R	A27	940R	ARJ	945A
DWA	527D	A2A	940R	ARK	945A
DWB	527D	A2B	940R	ARL	945A
DWC	527D	A2D	940R	AS8	856S
DWD	527D	A2E	940R	D7A	867I
DWE	527D	A51	940R	D7B	867I
DWG	527D	A52	940R	D7C	867I
DWH	527D	A54	940R	D7D	867I
DWJ	527D	A55	940R	D7E	867I
DWK	527D	A57	940R	D7H	867I
DWL	527D	A5A	940R	D7J	867I
DWM	527D	A5B	940R	D7K	867I
DWN	527D	A5D	940R	D7L	867I
DWQ	527D	A5E	940R	D7M	867I
DWR	527D	A5J	940R	D7Z	867I
DWT	527D	AC6	940R	None	140B
DWU	527D	ACJ	940R	DZB	888I
DWV	527D	AF6	940R	DZG	824R
DWX	527D	AFI	940R		